

MODEL 251CDLR HEAVY DUTY CHAIN DRIVEN LIVE ROLLER

24 HOUR SHIPMENTS INCLUDE LENGTHS 5'-0" TO 80'-0" AS DETAILED BELOW

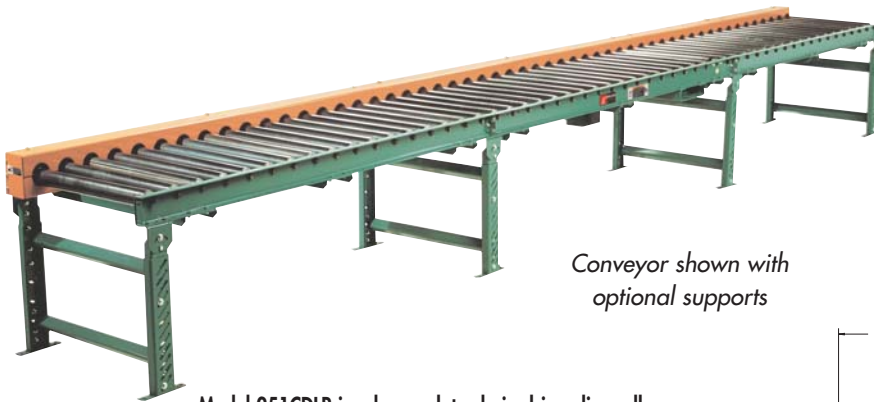

Conveyor shown with optional supports

Model 251CDLR is a heavy duty chain driven live roller conveyor, specifically designed to transport heavy loads such as tote pans, castings, drums, pallet loads, etc. It is especially suited for carrying loads in the presence of oil and other such contaminants.

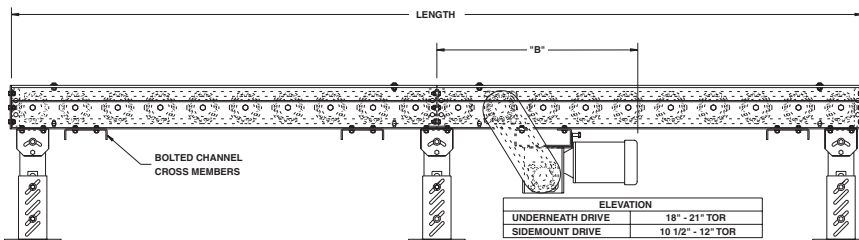
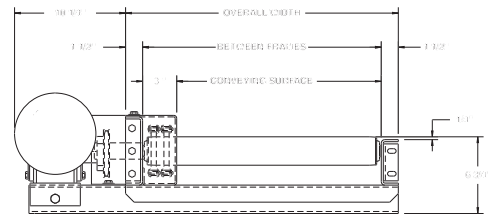
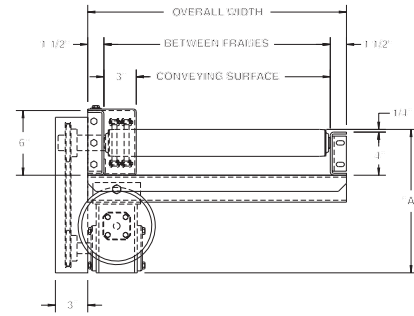

HP @ 35 FPM	"A"	"B" MAX.
3/4	13"	38-13/16"
1	13-1/4"	39-1/8"
1-1/2	14-1/8"	39-1/8"
2	15"	40-13/16"

SPECIFICATIONS

TREAD ROLLERS: 2-1/2" dia. x 11 ga. steel rollers, model 251S with sprockets.

CHAIN DRIVE: Roller to roller with No. 60 roller chain.

ROLLER CENTERS: 3", 4-1/2", 6", 9" or 12". (SEE NOTE FOR 3" RC)

CENTER DRIVE: Reversible drive either side mounted or underside mounted (specify). Main drive roller is supported by precision, heavy duty, lubricated, ball bearing units.

BED: 6" x 1-1/2" x 7 ga. and 4" x 1-1/2" x 7 ga. formed steel channel frame. Bed sections attached with couplings and floor supports.

MOTOR DRIVE: 3/4 HP, 230/460/3, 60 cycle, ODP right angle gear motor.

BEARINGS: Removable type, heavy duty ball bearings, zinc-plated, grease packed, labyrinth sealed. Roller bearings provide roller capacity of 540 lbs. per roller (maximum).

CHAIN GUARD: The chain drive is completely enclosed along the entire length of the conveyor.

BED LENGTHS (4-1/2" or 9" RC): Intermediate bed section lengths 3'-0", 3'-9", 4'-6", 5'-3", 6'-0", 6'-9", 7'-6", 8'-3", 9'-0" and 9'-9" increments. Minimum overall conveyor length with drive 5'-3". Maximum overall conveyor length: 58'-6" with 4-1/2" RC; 78'-0" with 9" RC.

BED LENGTHS (6" or 12" RC): Intermediate bed section lengths are available in 1'-0" increments. Minimum overall conveyor length with drive 5'-0". Maximum overall conveyor length 80'-0".

ELECTRICAL CONTROLS: Optional.

SPEED: 35 FPM, constant.

***NOTE 3" RC:** 3" RC are available with #40 chain on 40-14 double single sprocket sleeves.



OPTIONAL 3" RC NOW AVAILABLE
(guard removed for clarity)



■ 24 hour shipment

SPECIFICATION TABLE

UNIT WEIGHTS (FOR 4-1/2" AND 9" ROLLER CENTERS ONLY)																	
CONVEYOR LENGTH		5'-3"		9'-9"		19'-6"		29'-3"		39'-0"		48'-9"		58'-6"		68'-3" 78'-0"	
CONV. SURFACE	BF	4-1/2"RC	9"RC	4-1/2"RC	9"RC	4-1/2"RC	9"RC	4-1/2"RC	9"RC	4-1/2"RC	9"RC	4-1/2"RC	9"RC	4-1/2"RC	9"RC	9"RC	9"RC
12"	15"	317	282	522	452	928	788	1304	1099	1699	1427	2105	1763	2511	2099	2503	2844
18"	21"	347	307	577	497	1033	873	1455	1221	1899	1588	2355	1964	2811	2340	2753	3129
24"	27"	377	330	632	537	1138	948	1606	1328	2099	1729	2605	2140	3110	2551	3003	3414
30"	33"	407	352	687	577	1243	1023	1757	1435	2299	1870	2855	2316	3412	2762	3253	3699
36"	39"	443	373	753	613	1368	1088	1938	1528	2538	1993	3104	2419	3770	2945	3468	3944
42"	45"	472	395	807	652	1473	1163	2090	1636	2738	2134	3404	2645	4070	3156	3718	4229
48"	51"	500	415	862	692	1578	1238	2240	1743	2938	2275	3654	2821	4370	3367	3968	4514
51"	54"	516	428	890	713	1631	1277	2317	1799	3039	2348	3780	2913	4521	3477	4094	4657
54"	57"	532	440	917	732	1683	1313	2391	1850	3139	2418	3904	2998	4670	3579	4218	4799
60"	63"	567	460	982	767	1808	1378	2571	1943	3377	2539	4203	3150	5029	3761	4433	5044

UNIT WEIGHTS (FOR 6" AND 12" ROLLER CENTERS ONLY)																			
CONVEYOR LENGTH		5'-0"		10'-0"		20'-0"		30'-0"		40'-0"		50'-0"		60'-0"		70'-0"		80'-0"	
CONV. SURFACE	BF	6"RC	12"RC	6"RC	12"RC	6"RC	12"RC	6"RC	12"RC	6"RC	12"RC	6"RC	12"RC	6"RC	12"RC	6"RC	12"RC	6"RC	12"RC
12"	15"	299	287	482	432	848	728	1214	1064	1580	1380	1946	1699	2312	2012	2678	2328	3044	2644
18"	21"	324	297	527	467	933	813	1339	1159	1745	1505	2151	1851	2557	2197	2963	2543	3369	2889
24"	27"	349	312	572	502	1018	878	1464	1254	1910	1630	2356	2006	2802	2382	3248	2758	3694	3134
30"	33"	374	332	617	537	1103	943	1589	1349	2075	1755	2561	2161	3047	2567	3533	2973	4019	3379
36"	39"	399	348	662	563	1188	988	1714	1429	2240	1840	2766	2266	3292	2692	3818	3118	4344	3544
42"	45"	424	367	707	597	1273	1053	1839	1509	2405	1965	2971	2421	3537	2877	4103	3333	4669	3789
48"	51"	449	387	752	632	1358	1118	1964	1604	2570	2090	3176	2576	3782	3062	4388	3548	4994	4034
51"	54"	462	400	775	650	1401	1151	2027	1652	2653	2153	3279	2654	3905	3155	4531	3656	5157	4157
54"	57"	474	407	797	667	1443	1183	2089	1699	2736	2216	3381	2731	4027	3247	4673	3763	5319	4279
60"	63"	499	422	842	692	1528	1228	2214	1764	2900	2300	3586	2836	4272	3372	4958	3908	5644	4444

OPTIONAL EQUIPMENT

SPEED: Constant speed 1.5-100 FPM; DC variable speed; AC inverter variable speed. Other constant or variable speeds available. **NOTE: CAPACITY CHANGES WITH SPEED. 100 FPM MAX. WITH ROLL-TO-ROLL CHAIN DRIVE.**

FLOOR SUPPORTS: Supports, knee braces, casters and polytier supports available. See Conveyor Accessories.

ELECTRICAL CONTROLS: Magnetic starter (one direction or reversible); one direction manual starter; momentary start/stop push button station; forward/reversing/stop push button station; mounting and pre-wiring for units 12'-0" long and under; limit switch, photo relay; others available.

BED: 4" at 5.4 lb. and 6" at 8.2 lb. structural steel channel frame.

MOTORS: Available through 3 HP in TEFC, explosion proof, dirty duty, brake motor, 115/230/1, 575/3, etc.

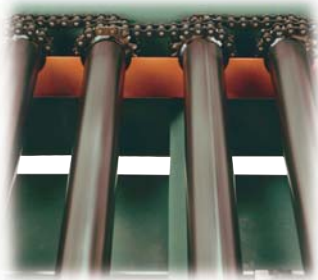

ROLLER TO ROLLER CHAIN DRIVE
(guard removed for clarity)



OPTIONAL TOP ROLLER GUARD MOUNTED DRIVE