

POWER ACCESSORIES

TURNING WHEEL/TURNING POST ASSEMBLY

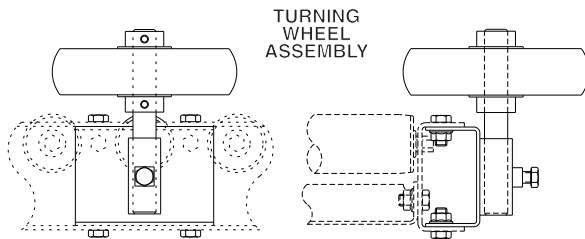

Turning wheel and turning post assemblies (turning post shown lower right) are commonly used in applications with converging or diverging spurs. These simple transition devices assist products with smooth transition to or from spur line.

SPECIFICATIONS

TW: 6" dia. x 1-1/2" wide face rubber wheel with 3/4" dia. bore; shaft is 3/4" dia. w/ locking collar positioned above and below wheel. Shaft adjusts vertically up/down to accommodate product height.

TP: 196S roller (medium duty) or 251S roller (heavy duty), both 6" BF mounted in 7 ga. frame assembly.



SPECIFY MODEL NUMBER PER EXAMPLE

TW-3.5

T(wheel or post)-(frame depth or roller size**)
 *Specify W for turning wheel or P for turning post.
 **For turning wheel specify frame size as 2.5, 3.5, 4.5 or 7. For turning post, indicate roller type as either 196 or 251.
 NOTE: TW is 24 hour shipment; TP is 2 week shipment.

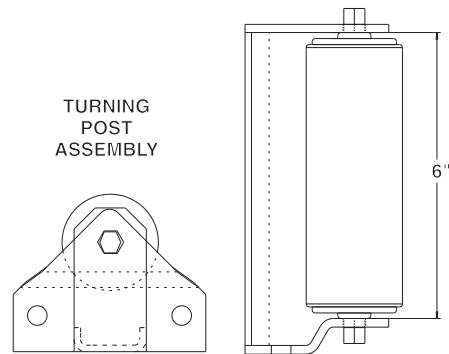

■ 24 hour shipment ■ 2 week shipment

CONNECTOR BRACKETS

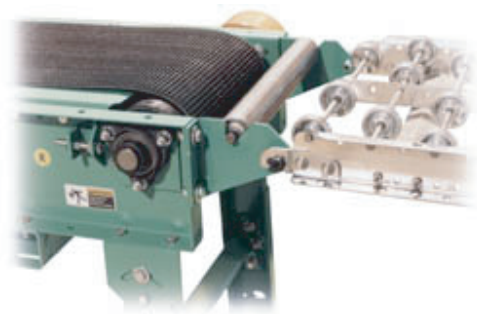

BRACKETS BELOW MODEL CB

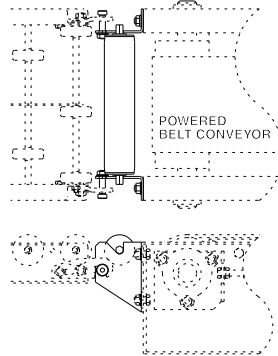

SPECIFY MODEL NUMBER PER EXAMPLE

CB-196-15

CB-(discharge gravity conveyor*)-(between frames)
 *Specify SW (for wheel conv.) 138, 196, 192, 199 or 251.

SPECIFY MODEL NUMBER FOR 350BOS

CBOS-4-24

CBOS-(pulley diameter*)-(overall width)
 *Available in 4" or 8" pulley diameter.

WARNING: Connector brackets are designed to eliminate pinch (or nip) points that exist when gravity conveyors are permanently attached to powered belt conveyors.

SPECIFICATIONS

CONSTRUCTION: Brackets are 10 ga. HRS painted steel and bolt at end of powered conveyor to butt couplings. Gravity conveyor attaches to connector bracket.

POP-OUT ROLLERS: Mounts into slot on bracket for safety design. Use of connector bracket eliminates dangerous pinch points.

MODEL NO.	GRAVITY MODEL
CB-SW	SKATE WHEEL
CB-138	1-3/8" DIA. x 18 GA.
CB-196	1.9" DIA. x 16 GA.
CB-192	1.9" DIA. x 12 GA.
CB-199	1.9" DIA. x 9 GA.
CB-251	2-1/2" DIA. x 11 GA.

BRACKETS BELOW, MODEL CBOS
4" PULLEY

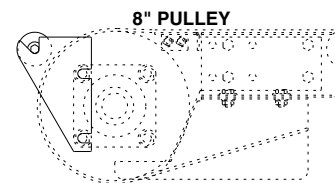
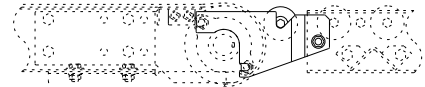

■ 24 hour shipment

