

MODEL 796LSX LINE SHAFT CROSS-OVER MODULE

24 HOUR SHIPMENTS INCLUDE ALL 1-FOOT INCREMENTS 2'-0" TO 10'-0"

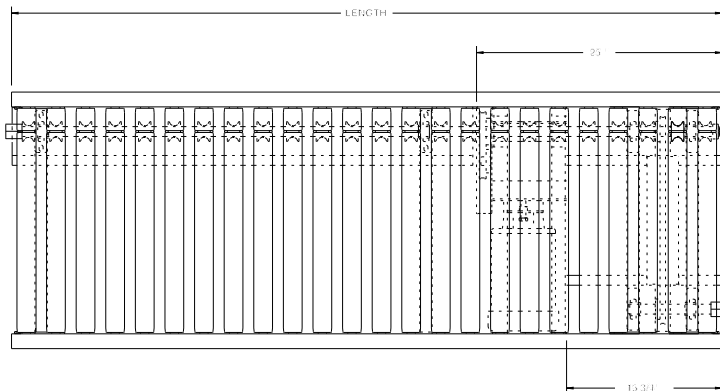

Roach cross-over module 796LSX was designed to offer a standard component to eliminate confusion over cross-overs. Available in 2'-10' lengths in 24 hours, Roach model 796LSX is the only component required to cross over drive shaft.



SPECIFICATIONS

TREAD ROLLERS: 1.9" dia. x 16 ga. steel, model 196S grooved.

DRIVE BELT: 3/16" dia., polyurethane belts. Nominal 15 lbs. per roller drive.

DRIVE SHAFT: 1" dia. C1018 cold rolled steel shaft.

COUPLINGS: Couplings located both ends or one end only. Specify where couplings required.

BEARINGS: Precision, lubricated, ball bearing units with composite housings.

SPEED: 60 FPM constant.

BED: 7" x 1-1/2" x 12 ga. formed steel channel frame.

FLOOR SUPPORTS: SM-6 adjustable 31-1/2" to 43-1/2" TOR. Supports should be lagged to floor.

MOTOR DRIVE: 1/3 HP, 230/460/3, 60 cycle, ODP right angle gear motor.

CROSS OVER DIRECTION: Specify "cross over to right hand" or "cross over to left hand".

ELECTRICAL CONTROLS: Optional.

SPECIFY MODEL NUMBER PER EXAMPLE

796LSX-21-3-10-R

796LSX-(between frames)-(roller centers)-(length)-(left or right)

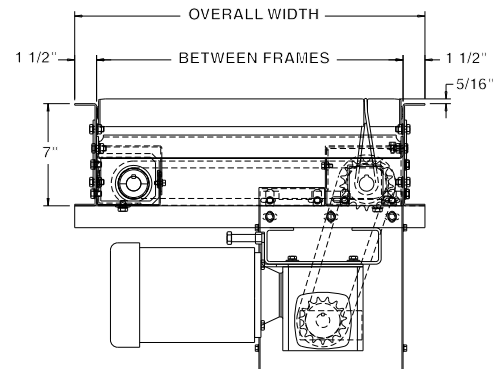

RC	3"	4"	6"	3"	4"	6"
BF	10' UNIT WEIGHTS			UNIT WEIGHTS / FT.		
15"	455	427	389	26	23	20
19"	487	453	419	29	25	22
21"	507	470	433	31	27	24
25"	536	494	451	35	31	27
27"	558	513	468	37	33	28
33"	601	548	495	43	39	32
39"	657	595	533	49	43	37

OPTIONAL EQUIPMENT

GUARD RAILS: 1-3/4" x 1" formed channel (model GC), adjusts horizontally to 8" wider than roller and vertically to 6" above roller; formed steel fixed (model FSG in 2", 4" & 6" heights); fixed channel (model FC); 1-1/2" angle (model GA1-1/2). See page 157.

FLOOR SUPPORTS: Other height supports, knee braces, casters, ceiling hangers and polytier supports available. See pages 152-155.

CONVEYOR SPEED: Constant speed 15-120 FPM; DC variable speed; AC inverter variable speed. MINIMUM operating speed for line shaft conveyor is 15 FPM.

ELECTRICAL CONTROLS: Magnetic starter (one direction or reversible); Others available. Consult factory.



■ 24 hour shipment