

MODEL 796LS LINE SHAFT DRIVEN LIVE ROLLER

24 HOUR SHIPMENTS INCLUDE ALL 1-FOOT INCREMENTS 2'-0" TO 100'-0"

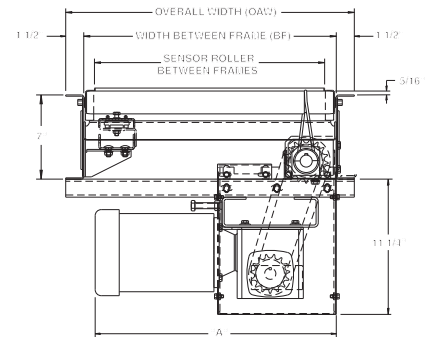

Roach 796LS line shaft driven conveyors have gained widespread usage with their unique design. Curves, spurs and a variety of modules may be driven by a SINGLE drive.

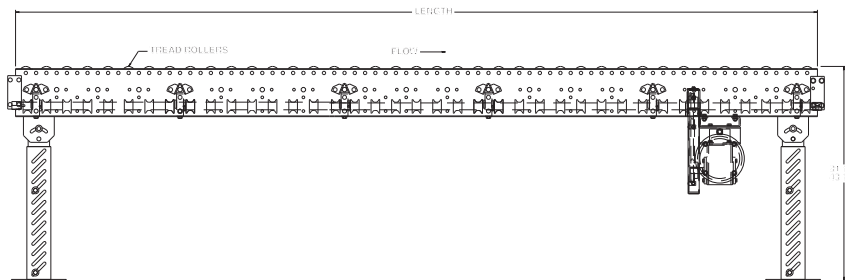

LINE SHAFT COUPLING CHART

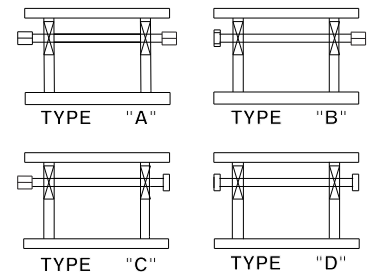

HP @ 60 FPM	REDUCER	"A" MAX.
1/3, 1/2	RBW11100-02	24"
3/4, 1	RBW11100-02	24"
1-1/2, 2	RBW11100-04	25-1/4"

SPECIFICATIONS

TREAD ROLLERS: 1.9" dia. x 16 ga. steel, model 196S grooved.

DRIVE BELT: 3/16" dia., polyurethane belts. Nominal 15 lbs. per roller drive.

DRIVE SHAFT: 1" dia. C1018 cold rolled steel shaft.

COUPLINGS: Couplings located both ends (type "A"), one end only (type "B" or "C") or none (type "D"). See 'line shaft coupling chart' and specify.

CENTER DRIVE: Reversible drive; located approximately 24" from end of bed section.

BEARINGS: Precision, lubricated, ball bearing units with composite housings.

SPEED: 60 FPM, constant.

BED: 7" x 1-1/2" x 12 ga. formed steel channel frame. Bed sections attached with splice plates and floor supports.

FLOOR SUPPORTS: SM-6 adjustable 31-1/2" to 43-1/2" TOR. Supports should be lagged to floor.

MOTOR DRIVE: 1/3 HP, 230/460/3, 60 cycle, ODP right angle gear motor.

ROLLER CHAIN: Drive shaft is driven by No. 50 chain. Chain take-up provided on motor base.

CAPACITY: See page 5 in technical section for load capacity rating.

ELECTRICAL CONTROLS: Optional.



SPECIFICATION TABLE

CONVEYOR LENGTH		2'	5'	10'	15'	20'	25'	30'	40'	50'	60'	70'	80'	90'	100'
BF	OAW	Unit weights (lbs.) with 3" roller centers (For other centers, deduct weights below)													
15"	18"	225	306	443	552	717	826	991	1265	1539	1813	2087	2361	2635	2909
19"	22"	236	326	475	624	773	922	1071	1369	1667	1965	2263	2561	2859	3157
21"	24"	249	345	495	655	815	1013	1135	1455	1775	2095	2415	2735	3055	3375
25"	28"	255	363	523	693	853	1018	1183	1513	1843	2173	2503	2833	3163	3493
27"	30"	260	374	545	716	887	1058	1229	1571	1913	2255	2597	2939	3281	3623
33"	36"	269	401	588	775	962	1149	1336	1710	2084	2458	2832	3206	3580	3954
39"	42"	288	438	643	848	1053	1258	1463	1873	2283	2693	3103	3513	3923	4333

Deduct the following weights (lbs.) for other than 3" centers

TREAD ROLLER CENTERS	15" BF		19" BF		21" BF		25" BF		27" BF		33" BF		39" BF	
	Per 5'	Per 10'	Per 5'	Per 10'	Per 5'	Per 10'	Per 5'	Per 10'	Per 5'	Per 10'	Per 5'	Per 10'	Per 5'	Per 10'
4"	-14	-28	-17	-34	-19	-37	-21	-42	-23	-45	-27	-53	-31	-62
6"	-28	-56	-34	-68	-37	-74	-42	-84	-45	-90	-53	-106	-62	-124

OPTIONAL EQUIPMENT

SIDE MOUNTED DRIVE: Provides overall conveyor height of 10".

FLOOR SUPPORTS: Other height supports, knee braces, casters and polytier supports available. See pages 152-155.

CEILING HANGERS: 5/8" dia. threaded rod with hardware to attach rods to conveyor. Provides 6' clearance between ceiling and TOR (furnished in place of floor supports). See page 153.

CONVEYOR SPEED: Constant speed 15-120 FPM; DC variable speed; AC inverter variable speed. **MINIMUM** operating speed for line shaft conveyor is 15 FPM.

GALVANIZED ROLLERS: Tread rollers available in galv. steel, model 196G.

GUARD RAILS: 1-3/4" x 1" formed channel (model GC), adjusts horizontally to 8" wider than roller and vertically to 6" above roller; formed steel fixed (model FSG in 2", 4" and 6" heights; fixed channel (model FC); 1-1/2" angle (model GA1-1/2). See page 157.

MOTORS: Available through 2 HP in TEFC, explosion proof, dirty duty, 115/230/1, 575/3, etc.

ELECTRICAL CONTROLS: Magnetic starter (one direction or reversible); One direction manual starter; Momentary start/stop push button station; Forward/reversing /stop push button. Mounting and pre-wiring for units up to 12' long.

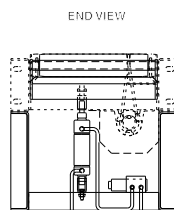
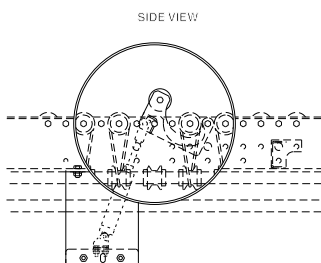

OPTIONAL PNEUMATIC ROLLER STOP



DRIVE SHAFT COUPLING

